



alpes

MAGNET



DNEVNE SOBE IN PREDSOBE

DNEVNI BORAVCI I PREDSOBLJA
LIVING ROOMS AND ENTRYWAYS

DNEVNE SOBE IN PREDSOBE ZA UDOBJE VAŠEGA DOMA.

Ljudje smo družabna bitja, življenjsko smo odvisni od srečevanja in druženja. Srečni smo lahko, če se naše socialno življenje odvija v urejenih, barvno usklajenih in našim potrebam prilagojenih prostorih. Prvi v vrsti takih prostorov je vsekakor naš dom, kjer je naš vpliv na urejenost bivalnega okolja lahko največji.

Po lastnih željah si uredimo dnevno sobo, ta glavni prostor druženja in počitka. Dragoceno je, če lahko opremo izberemo tako po količini, vrsti, barvah... Predsobo si kot prostor srečevanja, odhajanja in vračanja prav tako uredimo po lastnih idejah glede barv in oblik. Pri tem ne gre pozabiti na dodatne potrebe, kot sta shranjevanje oblačil, obutve in ne nazadnje – končni pogled v ogledalo.

Tako opremljeni prostori so privlačni tako za stanovalce kot za obiskovalce – pritegnejo nas k sebi. **MAGNET PAČ!**



DNEVNI BORAVCI I PREDSOBLJA ZA UDOBNOST VAŠEG DOMA.

Ljudi su društvena bića, naš život ovisi o susretima i druženju. Možemo biti sretni ako se naš društveni život odvija u urednim, bojama uskladenim i našim potrebama prilagođenim prostorima. Prvi u nizu takvih prostora svakako je naš dom, gdje naš utjecaj na uređenje okruženja u kojem boravimo može biti najveći.

Prema vlastitoj želji uređujemo dnevnu sobu, taj glavni prostor za druženje i odmor. Dragocjeno je ako opremu možemo odabrati kako po količini, tako i po vrsti, bojama... Predsoblje kao prostor u kojem se susrećemo, odlazimo i vraćamo također uređujemo prema vlastitim idejama u smislu boja i oblika. Pritom se ne smije zaboraviti na dodatne potrebe kao što je pohrana odjeće, obuće i, u konačnici, posljednji pogled u ogledalo prije odlaska.

Tako opremljeni prostori atraktivni su za stanare kao i za posjetitelje – jednostavno nas privlače.

MAGNET!

LIVING ROOMS AND ENTRYWAYS FOR THE COMFORT OF YOUR HOME.

Humans are social creatures, we are vitally dependent on meeting and socializing. We can be happy if our social life takes place in neat, colour-coordinated places, adapted to our needs. The first in a series of such places is definitely our home, where the influence we have on the arrangement of our living environment is the most prominent.

We can arrange our living room, that primary area for socializing and rest, according to our own wishes. It is valuable if we can choose the equipment according to quantity, type, colours... We can also arrange the hallway as a place for meeting, leaving, and returning, according to our own ideas regarding colours and shapes. At the same time, we should not forget about all the other needs, such as storing clothes, shoes, and last but not least – that final look in the mirror. Rooms furnished this way are attractive to residents and visitors alike – they draw us to them.

JUST MAGNETIC!

**DNEVNA
SOBA #01**

BC

HK

MAGNET

Dnevni boravak / Living room



Veliko prostora za shranjevanje, pa vseeno občutek svobode in prostornosti.

Puno prostora za odlaganje, ali uz osjećaj slobode i prostranosti.

Plenty of storage space - but still maintaining a feeling of freedom and spaciousness.



IZBRANI PREDMETI
POŽIVITEV
ZA OMARNI
SESTAV
VITRINI

ODABRANI
PREDMETI
U VITRINI -
ULJEPŠAVAJU
SVAKODNEVNI
IZGLED ORMARA

SELECTED ITEMS
IN THE SHOWCASE
- AN UPLIFT OF
THE CLOSET
SYSTEM



DNEVNA SOBA #02



MAGNET

Dnevni boravak / Living room



Viseče omare - boljša izraba prostora

Viseči ormari - za boljše iskorišten prostor

Floating closets - for a better use of space

Premišljeno izbrani kosi pohištva - za veliko svetlobe, zraka in odlagalnih površin.

Premišljeno odabrani komadi namještaja - za puno svjetla, zraka i površina za odlaganje.

Carefully selected pieces of furniture - for loads of light, air, and storage surfaces.

**DNEVNA
SOBA #03**

HK

MAGNET

Dnevni boravak / Living room



OMARE POD
TELEVIZORJEM
ELEKTRONI-
KA NA ENEM
MESTU

ORMARI ISPOD TELEVIZORA –
ELEKTRONIKA NA JEDNOM MJESTU

CABINETS UNDER TELEVISION – ALL
ELECTRONIC DEVICES IN ONE PLACE

**Enkratna postavitve
poskrbi za potrebe
vseh- v najljubših
barvah, poudarjenih z
naravno svetlobo.**

Jednokratno
postavljanje osigurava
potrebe sviju – u
omiljenim bojama,
naglašenim prirodnim
svjetlom.

A unique layout makes
sure everyone's
needs are met – in
their favorite colours,
accentuated by
natural light.

DNEVNA SOBA #04



MAGNET

Dnevni boravak / Living room



Radni kvatk zeljene
veličine – uskladen
s dnevnomo sobom

Home office of any
size – compatible
with the living
room

**Delovni kotichek poljubne
velikosti – skluden z dneвно sobo**

**Večkratna
uporabnost.
Vsak pri svojem
opravilu, pa
vendar v družbi
ljubih ljudi.**

Višenamjenska
upotrebljivost – svatko
uz svoj zadatak, ali ipak
u društvu ljudi koje
volimo.

Multipurpose –
everyone doing their
own work, but enjoying
the company of their
loved ones.

PREDSOBA

#01

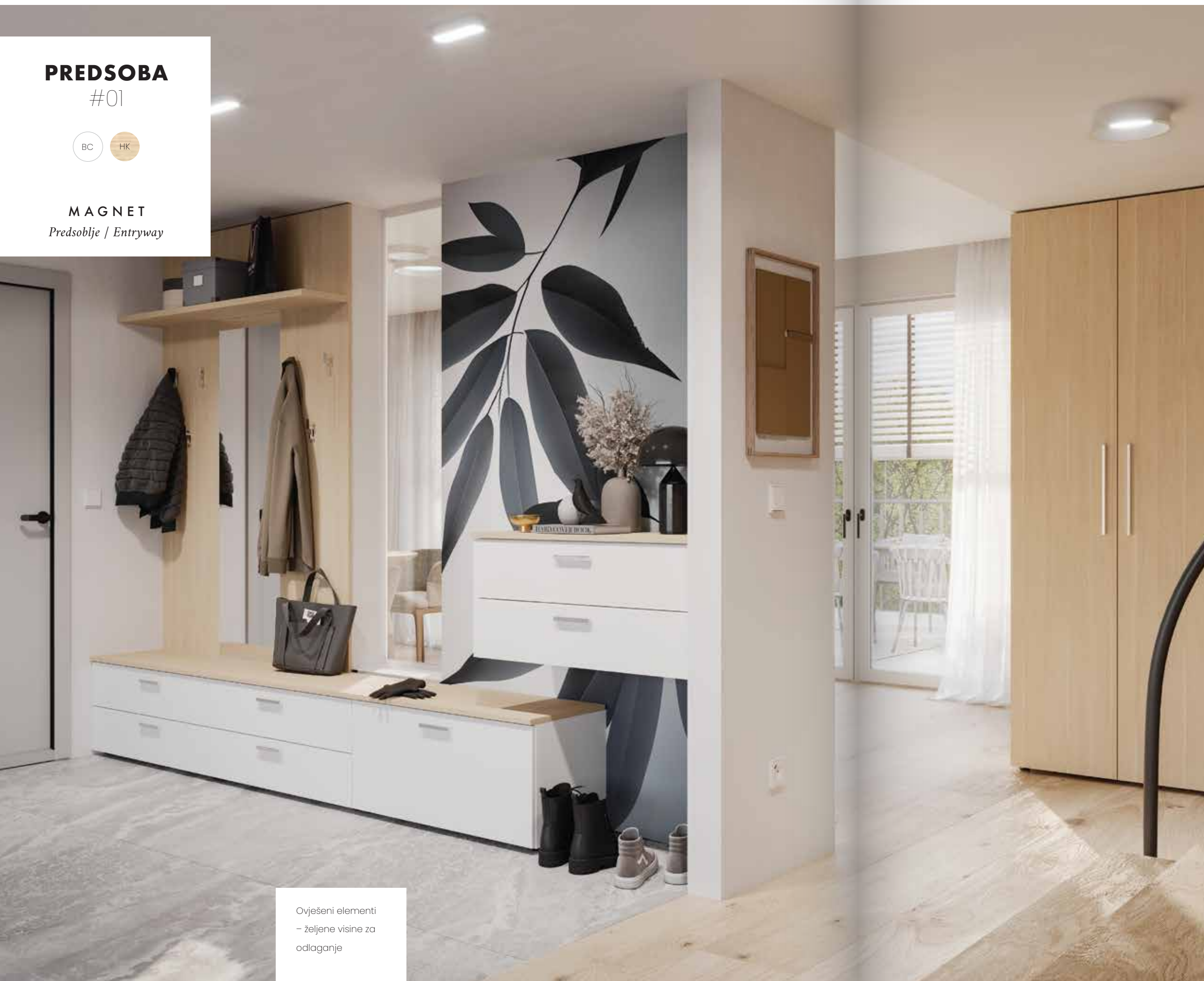
**MAGNET***Predsoblje / Entryway*

Ovješeni elementi
– željene visine za
odlaganje

Floating elements
– different height
options to put
things down

**Viseći elementi- poljubne
višine za odlaganje**

**Predsoba
za vse -
funkcionalna
ob odhodu,
vabljiva
ob vrnitvi
domov.**

Predsoblje za sve –
funkcionalno na odlasku,
privlačno
na povratku kući.

A entryway for everyone
– functional when
leaving, inviting when
returning home.



PREDSOBA

#02

**MAGNET***Predsoblje / Entryway*

**Odprto in zaprto se
dopolnjuje- izpolnjene
so vse naše potrebe.**

Otvoreno i zatvoreno se
dopunjuje – ispunjene su
sve vaše potrebe.

Open and closed elements
complement each other –
all our needs are met.

ZRCALO U KOMBINACIJI
S POLICAMA – DODATNA
MOGUĆNOST ODLAGANJA

MIRROR, COMBINED WITH
SHELVES – ADDITIONAL
STORAGE OPTION

DODATNA
MOŽNOST
SHRANJE-
VANJA

OGLEDALO U
KOMBINACIJI
S POLICAMI



PREDSOBA

#03

HK

MAGNET*Predsoblje / Entryway*

Vanjsko vješanje
na vješalicu – za
prozračivanje
odjeće

**Zunanje obešanje na
obešalnik – za zračenje olačil**

External hanger –
to air the clothes

**Preprosto
moderno –
s pridihom
enostavne
uporabnosti.**

Jednostavno
moderno – s
notom jednostavne
praktičnosti.

Simply modern –
with a touch of
functionality.



Senčeni deli imajo možnost vseh barv. Zasjenjeni dijelovi imaju mogućnost svih boja. Shaded parts are available in all of the colours. KA BC HK

OSNOVNI ELEMENTI / OSNOVNI ELEMENTI / BASIC ELEMENTS

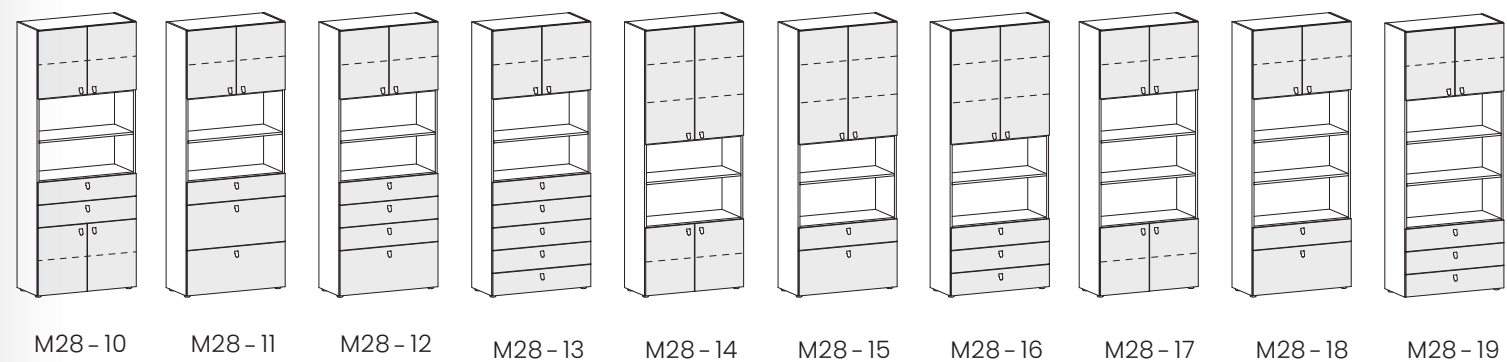
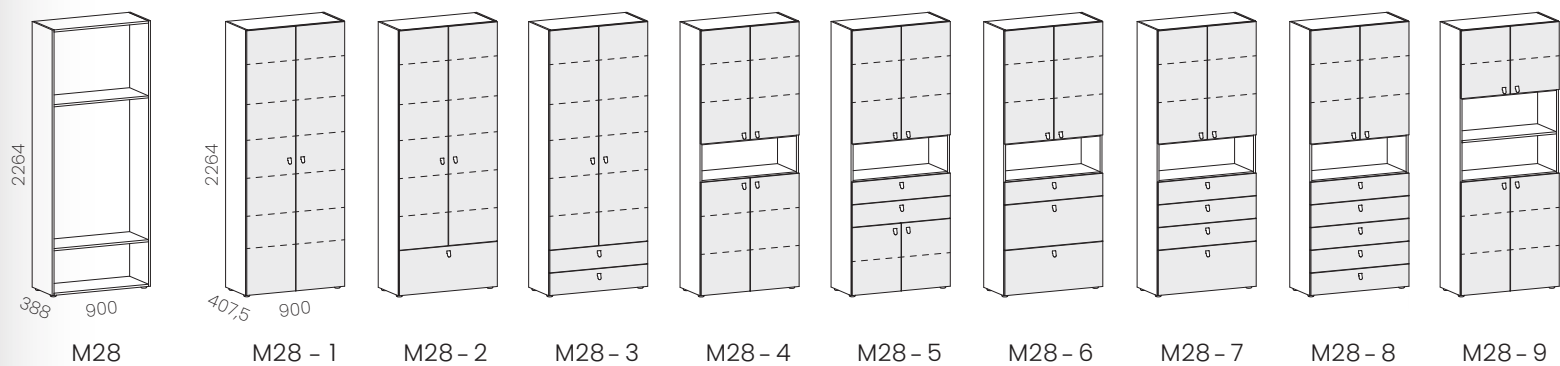
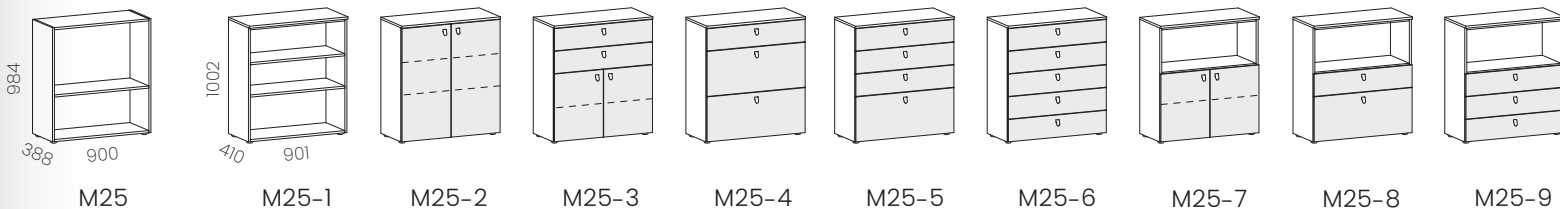
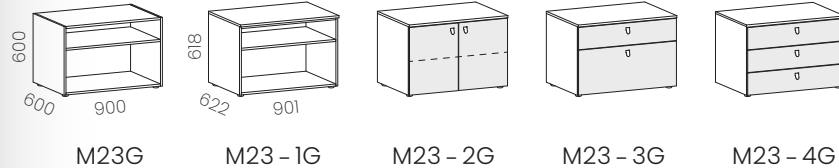
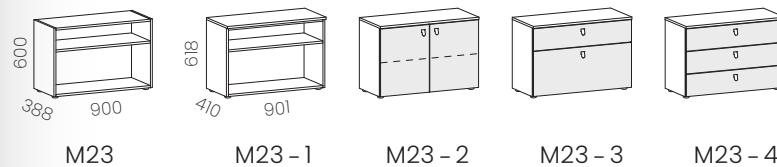
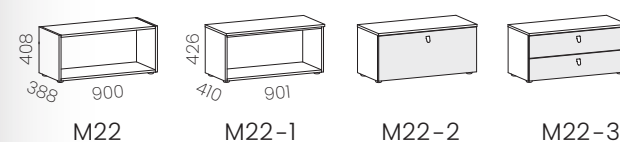
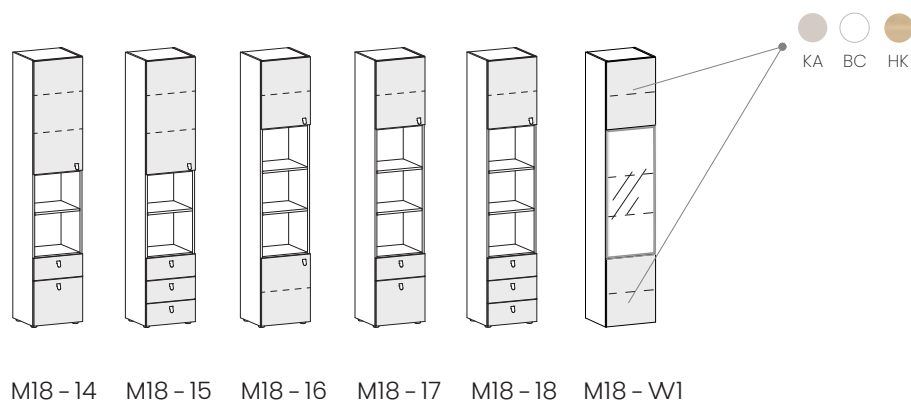
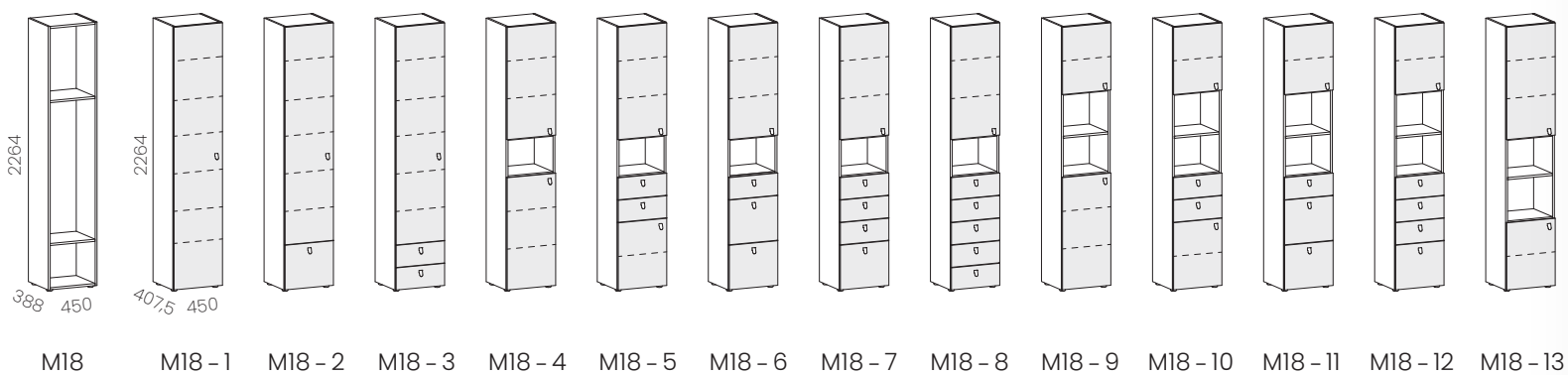
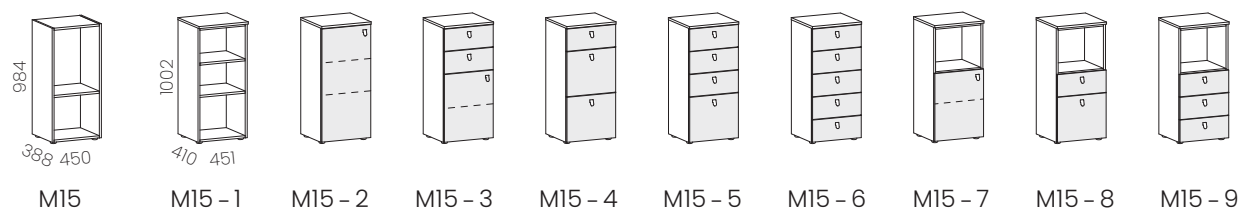
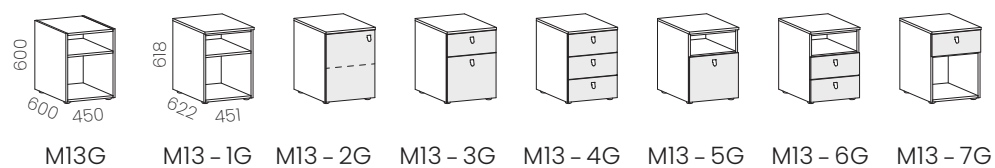
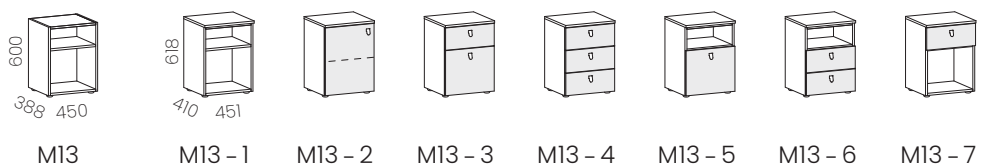
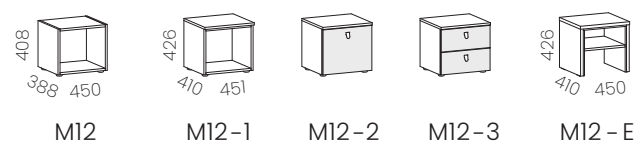

GARDEROBNI ELEMENTI / GARDEROBNI ELEMENTI / WARDROBES

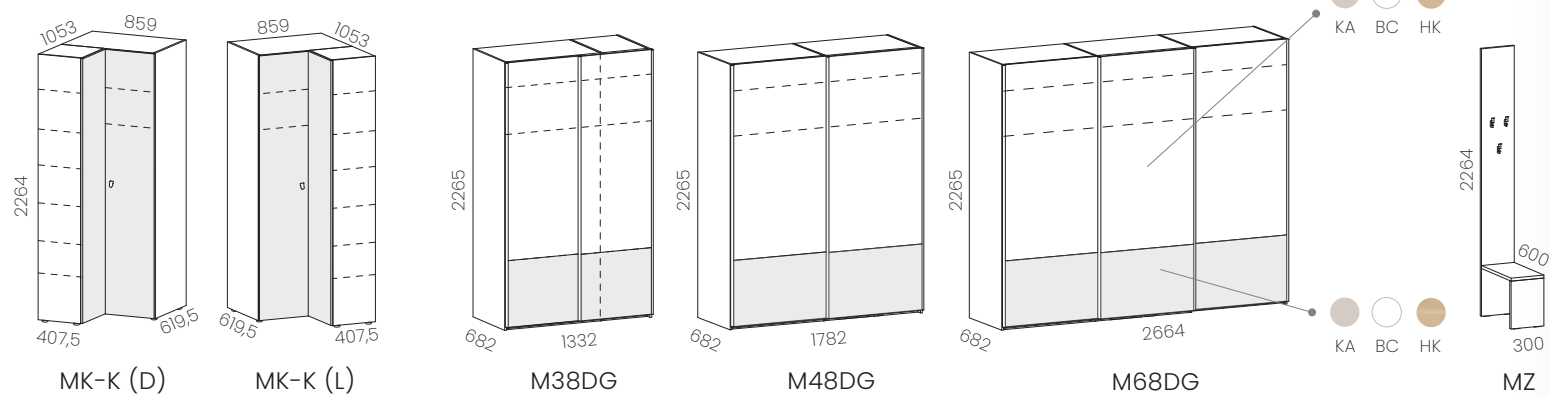
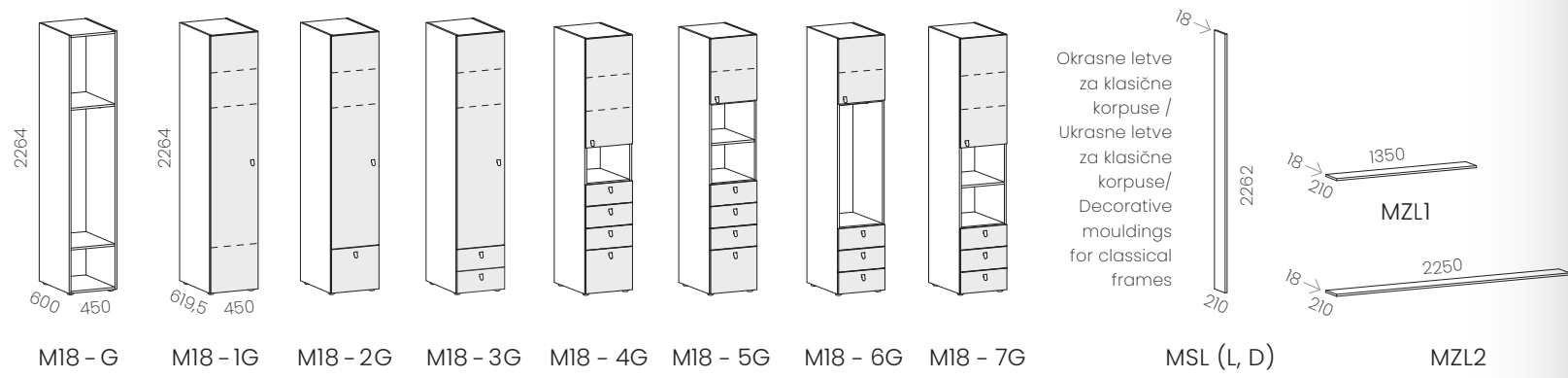

ni možna uporaba dodatkov garderobnih omar
/ nije moguće koristiti dodatke garderobnih ormara
/ it is not possible to use wardrobe interior elements

DODATKI GARDEROBNIH OMAR / DODACI GARDEROBNIH ORMARA / WARDROBE INTERIOR ELEMENTS

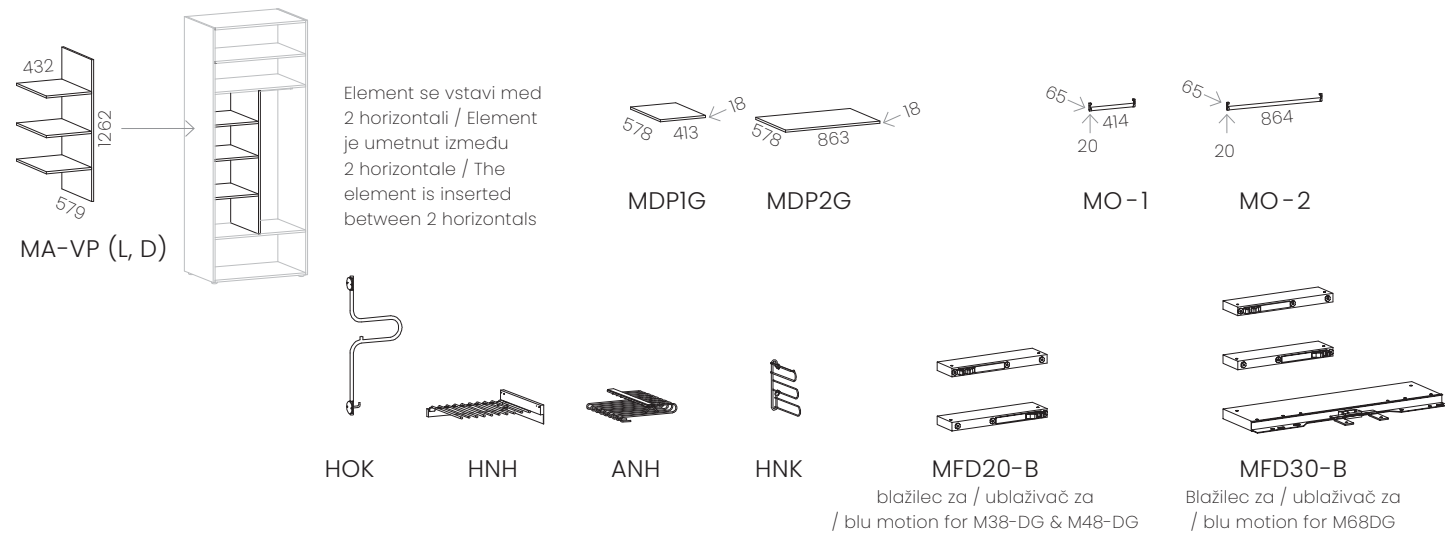

DODATNI ELEMENTI / DODATNI ELEMENTI / SUPPLEMENTAL ELEMENTS

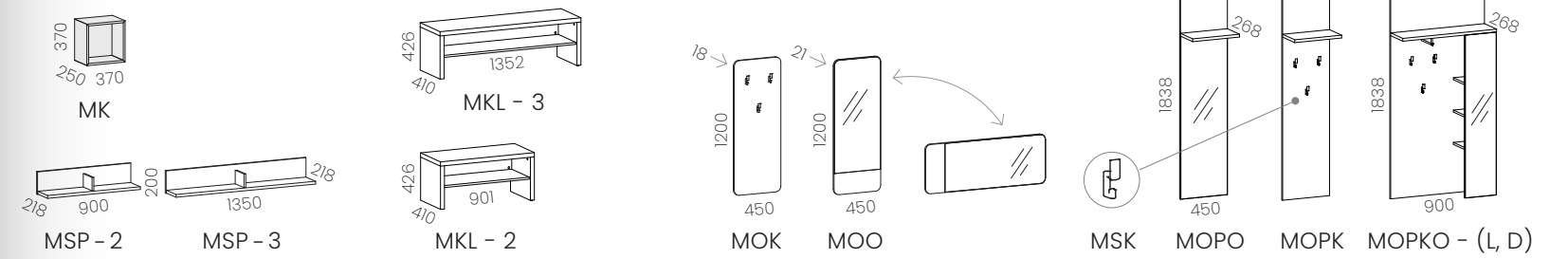

VIŠEČI ELEMENTI / VIŠEĆI ELEMENTI / WALL MOUNTED ELEMENTS

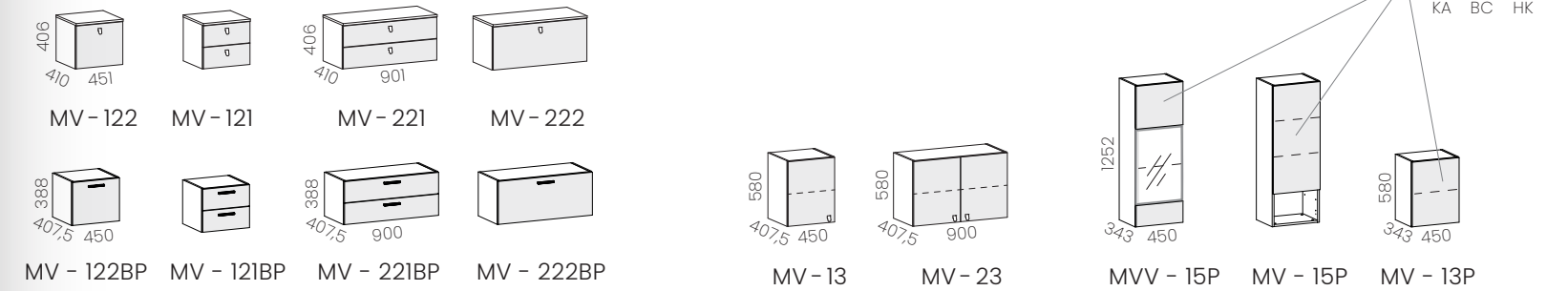

FRONTE / VRATA I LADICE / DOORS AND DRAWERS

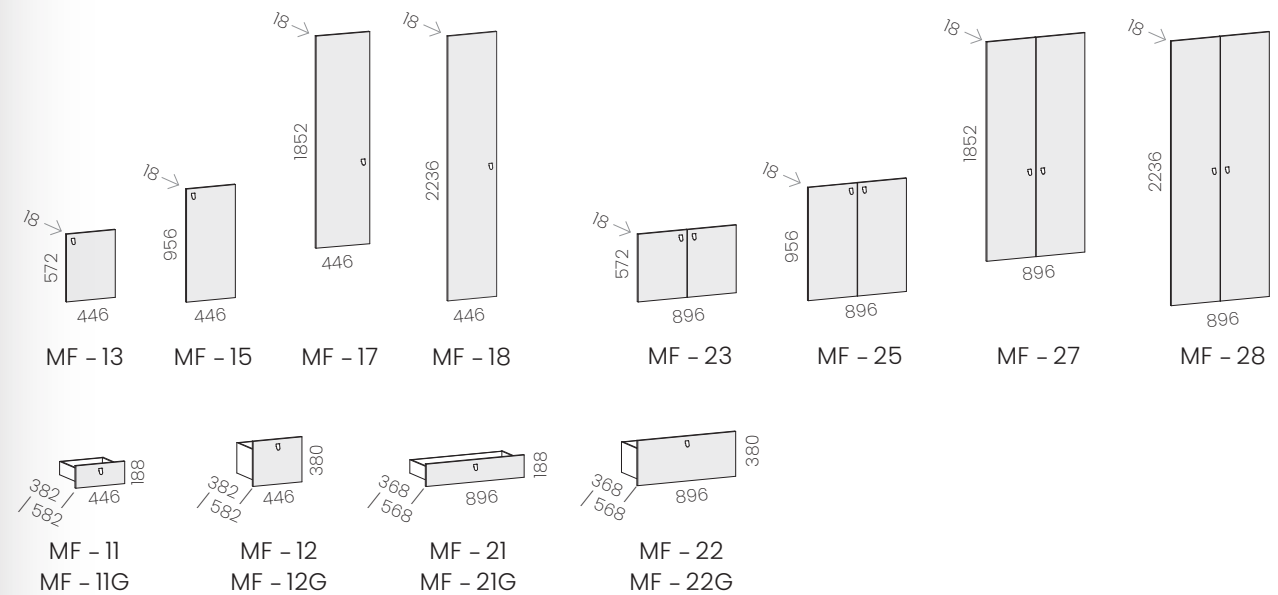

POKRIVNE PLOŠČE / POKRIVNE PLOČE / TOP PANELS

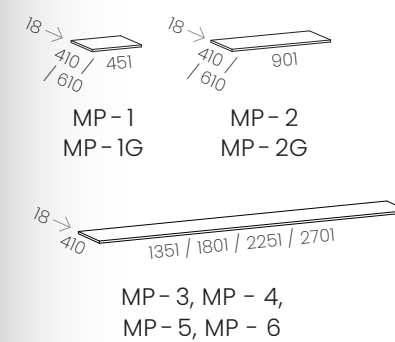

DODATNE POLICE / DODATNE POLICE / ADDITIONAL SHELVES

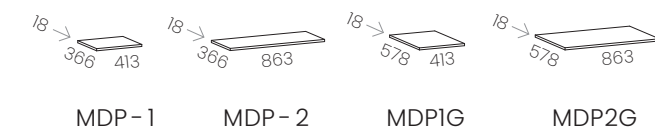

VMESNE POLICE / VEZNA POLICE / BRIDGE SHELVES

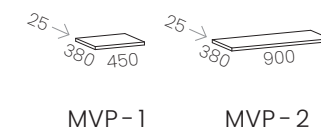

SVETILA / SVJETILJKE / LIGHTS



TV NASTAVKI / TV NASTAVKI / TV UPPERPART

Pod TV nastavkom kombiniramo elemente spodaj / Ispod TV nastavka kombiniramo donje elemente. / Under the TV upperpart, we combine the elements below.
Najveći možni razpon ploče bez podpore je 1350 mm! / Maksimalni mogući raspon ploče bez nosača je 1350 mm!
/ The maximum possible span of the panel without support is 1350 mm!

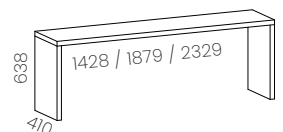

MTV3 - O / MTV4 - O /
MTV5 - O

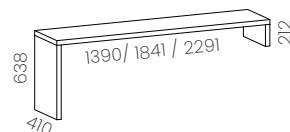

MTV3 - N / MTV4 - N /
MTV5 - N (L, D)

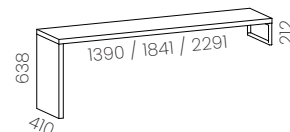

MTV3 - NK / MTV4 - NK /
MTV5 - NK (L, D)

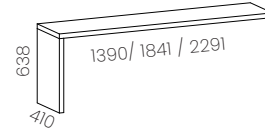

MTV3 - NR / MTV4 - NR /
MTV5 - NR (L, D)

ELEMENTI POD TV NASTAVKOM / ELEMENTI ISPOD TV NASTAVKA / ELEMENTS UNDER THE TV UPPERPART

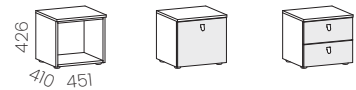

M12-1

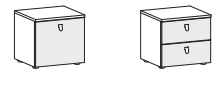

M12-2



M12-3

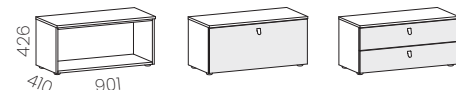

M22-1

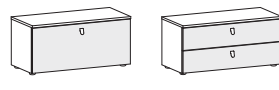

M22-2

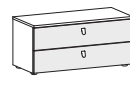

M22-3

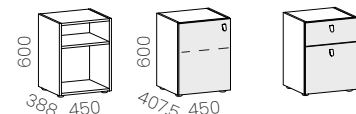

M13 - 1BP

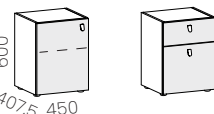

M13 - 2BP

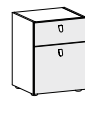

M13 - 3BP

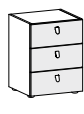

M13 - 4BP



M13 - 5BP

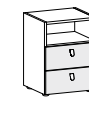

M13 - 6BP



M13 - 7BP

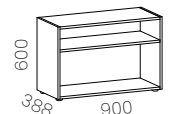

M23 - 1BP

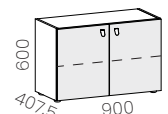

M23 - 2BP

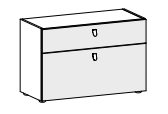

M23 - 3BP



M23 - 4BP

KLUBSKE MIZICE / KLUPSKI STOLIĆI / COFFEE TABLES

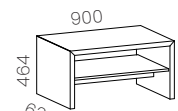

MKM - 90

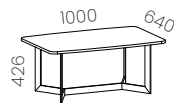

MKM - K100

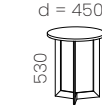

MKM - K45

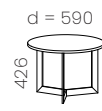

MKM - K60

PISALNE MIZE / PISAĆI STOLOVI / WRITING DESKS

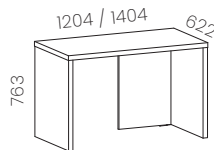

MPMIO (L, D)
MPM2O (L, D)

na slici je L izvedba
na slici je L izvedba
the picture shows L version

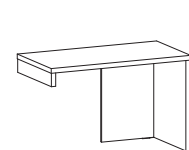

MPMIN (L, D)
MPM2N (L, D)

na slici je L izvedba
na slici je L izvedba
the picture shows L version

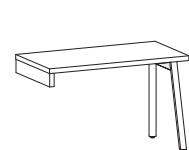

MPMINK (L, D)
MPM2NK (L, D)

na slici je L izvedba
na slici je L izvedba
the picture shows L version

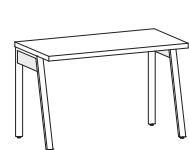

MPMIK
MPM2K

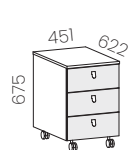

MP

MUKČ (črna / crno / black)



MUKV (alu)
uvodnice za kabele
uvodnice kabela
glands for cables

SESTAVNI DELI PISALNIH MIZ PO MERI / KOMPONENTE PISAĆIH STOLOVA PO MJERI / COMPONENTS FOR CUSTOM MADE WRITING DESK

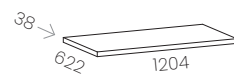

MPPL 1

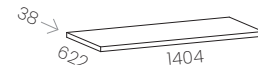

MPPL 2



MPPL

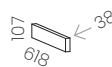

MNI

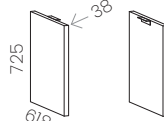

MN2(L) MN2(D)

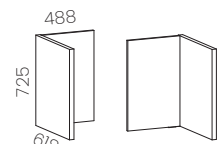

MN3(L) MN3(D)

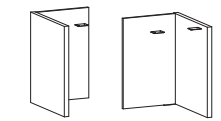

MN3K(L) MN3K(D)

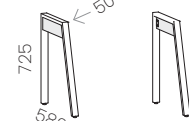

MNK(L) MNK(D)

BARVE dekori / decors

MAGNET

MOŽNE BARVNE KOMBINACIJE OSNOVNIH ELEMENTOV
MOGUĆE KOMBINACIJE BOJA OSNOVNIH ELEMENTA
AVAILABLE COLOUR COMBINATIONS OF BASIC ELEMENTS

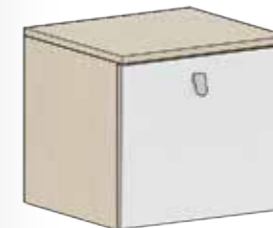

Primer:
Primjer:
Example:

HK/HK/BC

BC/HK/BC

Barve korpusa / Barve pokrivne plošče / Barve fronta
Boje korpusa / Boje pokrivne ploče / Boje fronta
Frame colours / Top panel colours / Colours of doors and drawers

Barve korpusa / Boje korpusa / Frame colours



Barve pokrivne plošče / Boje pokrivne ploče / Top panel colours

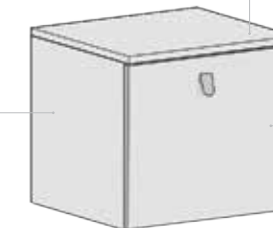

BC/BC/BC

Barve fronta / Boje fronta /
Colours of doors and drawers



V katalogu so fronte senčene s sivo.
U katalogu su fronte zasjenjene sivom bojom.
In the catalogue, front panels are shaded with gray.

BARVE FRONTA
/ BOJE FRONTA
/ COLOURS OF DOORS
AND DRAWERS

V katalogu so fronte senčene s sivo.
U katalogu su fronte zasjenjene sivom bojom.
In the catalogue, front panels are shaded with gray.

BARVE KORPUSA
/ BOJE KORPUSA
/ FRAME COLOURS

BC

bela iveral / bijela / white



hrast / hrast / oak



hrast / hrast / oak

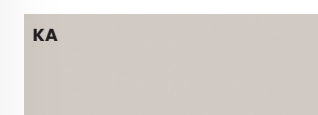

kašmir siva / kašmir siva / cashmere grey

BC

bela iveral / bijela / white

Dekorativni elementi, uporabljeni pri vizualizaciji, niso del prodajnega programa Magnet. Pridržujemo si pravico do tehničnih sprememb. **Oblikovanje pohištva:** Design team Alpes, Dana Poljanec, udia. **Tekst:** Marjana Rejc, udia. **Tisk:** Sinet d.o.o., 2023 **Oblikovanje:** www.leparec.si, **Vizualizacije:** www.arhivis.si

Dekorativni elementi koji su upotrijebljeni kod vizualizacija nisu dio prodajnog asortimana programa Magnet. Pridržavamo pravo tehničkih promjena. **Dizajn namještaja:** Design team Alpes, Dana Poljanec, arh., **Tekst:** Marjana Rejc, arh. **Tisk:** Sinet d.o.o., 2023 **Dizajn:** www.leparec.si, **Vizualizacije:** www.arhivis.si

Decorative elements used in renderings are not part of the Magnet sales programme. Alpes reserves the right to change items. **Furniture design:** Design team Alpes, Dana Poljanec, arch. **Press:** Sinet d.o.o., 2023, **Text:** Marjana Rejc, arch., **Ad&renderings:** www.arhivis.si, www.neagencija.si

Barve v katalogu lahko odstopajo od originalne barve izdelkov. / Boje v katalogu mogu biti različite od stvarne boje proizvoda. / The colours in the catalogue may deviate from the original colour of the products.

ROČAJI / RUČKE / HANDLES

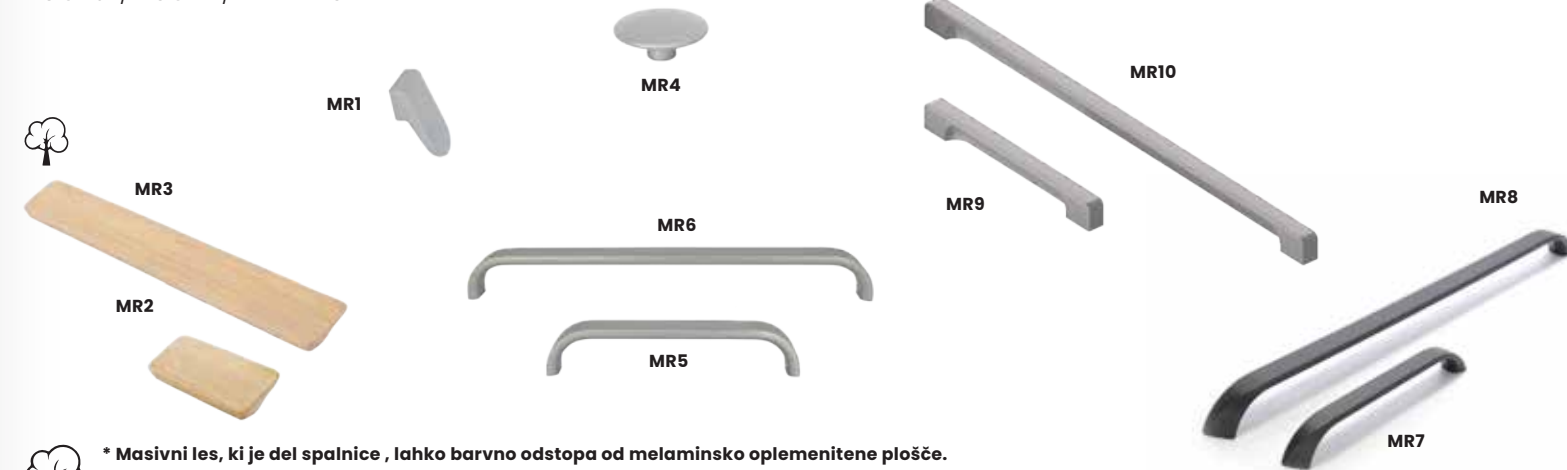

* Masivni les, ki je del spalnice, lahko barvno odstopa od melaminsko oplemenitene plošče.
* Masivno drvo koje je dio spavaće sobe bojom može odstupati od ploče oplemenjene melaminom.
* The solid wood that is a part of the bedroom may deviate in colour from the melamine-treated board.

